



**UltimateAir, Inc.**  
178 Mill Street  
Athens, Ohio 45701

Tel: 740-594-2277  
Fax: 740-592-1499  
[www.ultimateair.com](http://www.ultimateair.com)

## 12" Water-to-Air Coil Module *Instruction / Installation Guide*





## User Guide

Thank you for purchasing the UltimateAir 12" Water-to-Air Coil Module for use with your **RecoupAerator**<sup>®</sup>. The coil module, as described and installed here, is designed to be a pre and/or post air tempering option with BTU being delivered via the fans within the RecoupAerator, or external to the coil module.

## Installation

Overview:

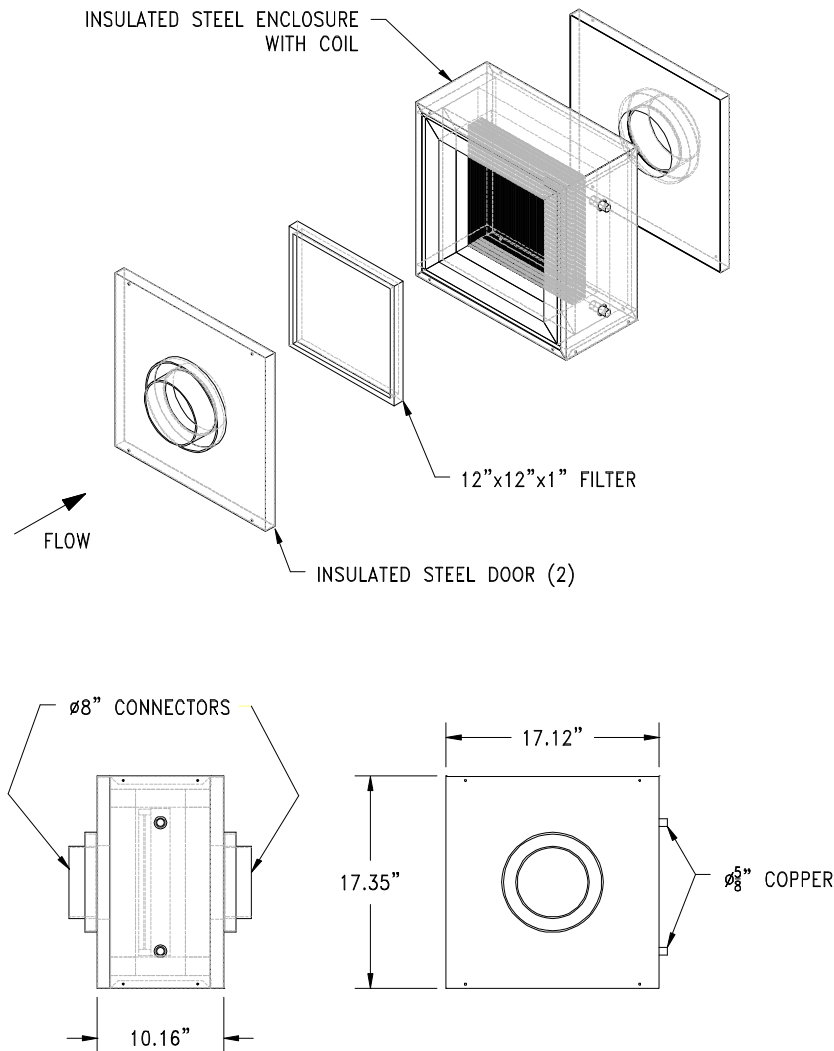

Note: Cabinet is insulated with a minimum of 1" expanded polystyrene, thermally broken from coil.



### 1. FOR USE AS POST HEAT (SPACE CONDITIONING)

The UltimateAir 12" Water-to-Air Coil Module connects to the "Fresh Air In" Duct to inside (noted as Duct 2 on the label). Be sure that the air flow direction is consistent between the air stream, and the diagram provided. Screws, mastic, and/or metal tape are required after making the connection. It is important that no air leakage is possible. See drawing below for details.

#### POST HEAT INSTALLATION CONNECT TO DUCT 2

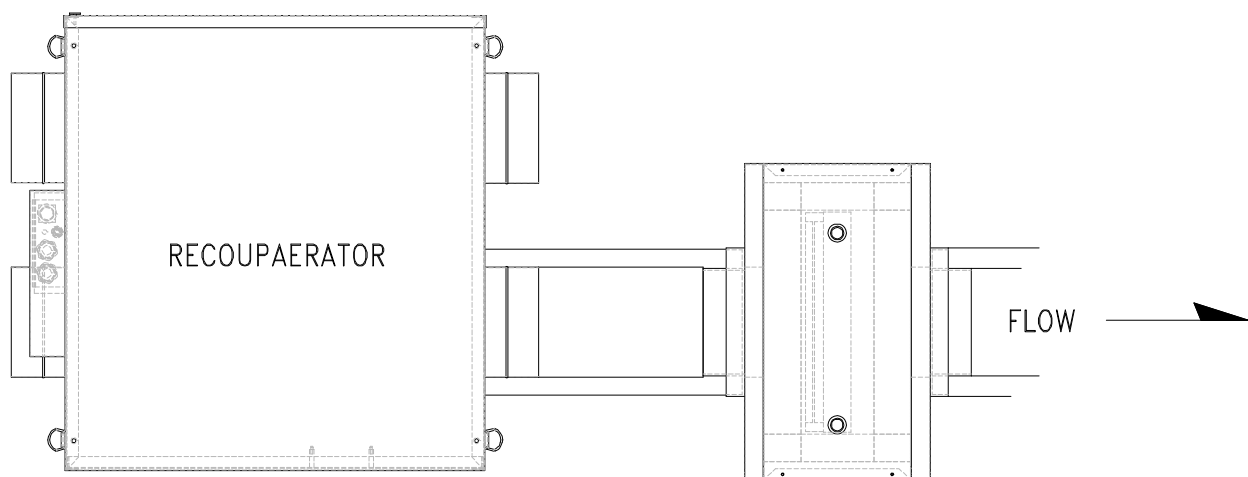

### 2. FOR USE AS PRE HEAT (DEFROST) OR PRE-COOLING/DEHUMIDIFICATION

The UltimateAir 12" Water-to-Air Coil Module connects to the "Fresh Air In" Duct to outside (noted as Duct 1 on the label). Be sure that the air flow direction is consistent between the air stream, and the diagram provided. Screws, mastic, and/or metal tape are required after making the connection. It is important that no air leakage is possible. This duct must be insulated from outside to surface of Recoupaerator steel casing. The coil itself is insulated already. See drawing below for details.



PRE HEAT INSTALLATION  
CONNECT TO DUCT 1

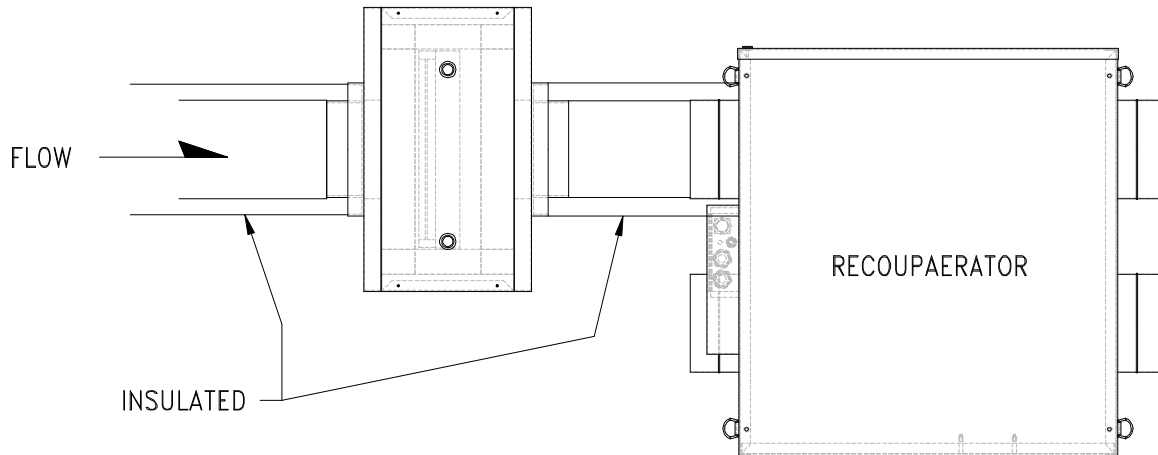

### CONDENSATE PAN INSTALLATION AND USE

For installations that will be condensing moisture out of the air stream passing through the coil (pre cooling application), a condensate pan installation will be required. Please request this pan when ordering, or obtain similar in the field.

Orient the coil to set in the pan, convenient for your plumbing scenario. Once orientation is determined, fix small rubber spacers to the bottom of the coil box, to space the coil box just off of the inside of the pan. This will allow water to easily flow to the drain at the end. Ensure the pan is level, or slightly lower at the drain end.

Connect a suitable 0.5" ID hose to the drain tube welded to the condensate pan, and run to appropriate location that will freely dispense of the condensate. Note that a pump will be necessary if the disposal location is higher than the pan (not provided). If relying on gravity, keep the length and elbows of the tube to a minimum.

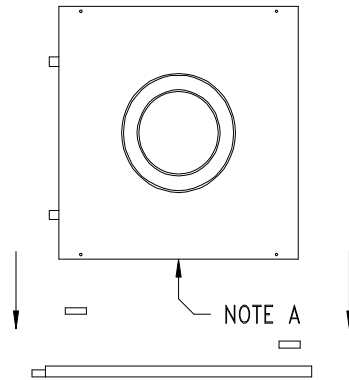
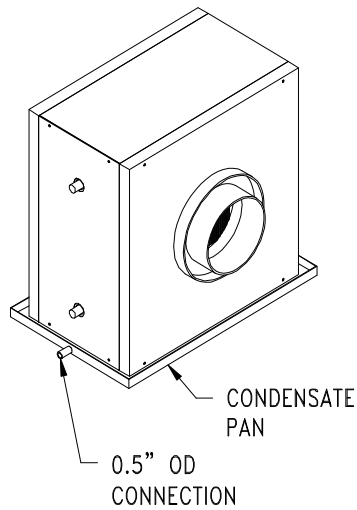

NOTE A: Drill a minimum 3/8" hole through the sheet metal in the middle of this area to allow better free flow of water out of the coil box. Drill only through the sheet metal.

**Coil Performance Data**

Test	Inlet Water <i>F</i>	Water Flow <i>GPM</i>	Air Flow <i>CFM</i>	Inlet Air <i>F</i>	Outlet Water <i>F</i>	Outlet Air <i>DB F</i>	DP Fan <i>in. wg.</i>	Capacity <i>Btu/hr</i>
<b>Options For Post Heat (Space Conditioning)</b>								
1	160	2.5	200	55	152.8	95.7	TBD	8777
2	160	2.5	200	65	153.5	102.0	TBD	7,972
3	160	5.0	200	65	156.6	103.9	TBD	8,393
4	160	2.0	100	65	153.7	123.5	TBD	6,220
5	120	2.0	200	65	115.5	85.9	TBD	4,452
6	120	5.0	200	65	118.1	87.2	TBD	4,783
7	120	2.5	100	65	117.1	98.8	TBD	3,585
8	110	2.0	200	65	106.3	82.1	TBD	3,621
9	110	5.0	200	65	108.4	83.1	TBD	3,902
10	100	2.0	200	65	97.2	78.1	TBD	2,824
11	100	5.0	200	65	98.8	79.0	TBD	3,025
<b>Options For Pre Heat</b>								
1	55	2.5	100	0	52.4	30.3 *	TBD	3,266
2	55	5.0	100	0	53.6	31.7	TBD	3,423
3	55	2.5	100	-10	51.9	25.5	TBD	3,833
4	55	2.5	100	-20	51.5	20.5	TBD	4,369
5	45	2.5	70	-20	42.1	28.9	TBD	3,692

\*This column pertinent as RecoupAerator requires incoming air be above 10 F



Test	Inlet Water <i>F</i>	Water Flow <i>GPM</i>	Air Flow <i>CFM</i>	Inlet Air <i>F</i>	Inlet Air <i>RH %</i>	Outlet Water <i>F</i>	Outlet Air		DP Fan <i>in. wg.</i>	Capacity Btu/Hr		
							<i>WB F</i>	<i>DB F</i>		<i>Total</i>	<i>Sensible</i>	<i>Latent</i>
<b>Options For Pre Cooling and Dehumidifying</b>												
1	50	2.5	100	95	52.5	54.2	67.4	71.8	TBD	5176	2538	2638
2	50	2.5	200	95	52.5	54.9	72.9	80.3	TBD	6,224	3224	3001
3	50	5.0	200	95	52.5	52.6	72.4	79.4	TBD	6,606	3411	3195

The UltimateAir 12” Water-to-Air Coil Module is designed for use as pre heat / pre cool, and/or post heat or post cooling, in conjunction with, or not in conjunction with an energy recovery ventilation unit.

Suggested applications:

1. Pre heat for energy recovery ventilation device (hot water or ground loop)
2. Pre cooling/dehumidification for energy recovery ventilation device (chilled water or ground loop)
3. Post heat (space heat)
4. Post cooling/dehumidification (chilled water)

## MAINTENANCE

Your coil comes installed with a dust collection filter. This filter will help protect the fin and coil from collecting with dust and debris. This filter will likely need to be changed once every 6 months of continuous air flow operation, depending on your specific inside and outside conditions. The outside dimension of the filter measure 12”w x12”h x 1”d. Please contact UltimateAir for purchasing, or sourcing of replacement filters. They are widely available in the field. When installing a new filter, ensure that the resistance across the replacement filter does not exceed the original design static pressure of the duct system for the air moving fan.

The coil should be visually inspected and cleaned once a year. If there is build up of dirt and/or debris on the fin surfaces, or coil surfaces, these surfaces should be rinsed clean with warm water (using some form of pressurized water is recommended).

Please call for more information regarding how to set up and control your individual need, if design assistance is required.

UltimateAir® Inc  
800-535-3448